

We do not yet understand the origin of longitudinal magnetoconductance in a single ellipsoid. However, our work provides clear-cut evidence for the failure of the Herring-Vogt model for the case of strong impurity scattering.\*

\* *Note added in proof.*—Recent magnetoresistance measurements by the author in collaboration with W. E. Howard indicate that the deviations from the symmetry relation are small for samples with carrier concentrations as high as  $3 \times 10^{16}$  and that the deviations reported in Sec. 6 are probably due to small systematic errors. A report of this new work is being prepared for publication.

## 7. ACKNOWLEDGMENTS

The author wishes to thank Dr. H. F. John and Mr. R. G. Seidensticker for their advice and assistance in preparing the low-resistance electrodes for the magnetoconductance disks. He also wishes to acknowledge stimulating discussions with Dr. E. N. Adams, Dr. M. Glicksman, and Dr. R. W. Keyes on the subject matter of this paper and to thank Dr. Glicksman for making some of his experimental results available prior to publication.

PHYSICAL REVIEW

VOLUME 109, NUMBER 2

JANUARY 15, 1958

## X-Ray Study of Deuteron-Irradiated Copper near 10°K\*†

R. O. SIMMONS AND R. W. BALLUFFI  
*University of Illinois, Urbana, Illinois*

(Received July 1, 1957)

Precise measurements of lattice expansion of high-purity copper held near 10°K during deuteron bombardment were made using a rotating single-crystal method. An expansion of  $(4.1 \pm 0.2) \times 10^{-21}$  per 7-Mev deuteron/cm<sup>2</sup> was found. No broadening of the Laue-Bragg intensity around the (4,0,0) reciprocal lattice point occurred. These effects are broadly consistent with the introduction of small point centers of dilatation. On the assumption that the damage consists of Frenkel defects, published calculations for the volume expansion due to interstitial atoms and vacant lattice sites in copper and the observed expansion lead to a concentration of defects which is only 0.08 to 0.22 of that predicted by the simple theory of displacement. Several independent measurements of inhomogeneity of the damage indicated an  $E^{-1}$  variation of the probability of lattice-atom displacement

with deuteron energy,  $E$ , in agreement with the simple theory. The ratio of resistivity increase (as determined by Cooper *et al.*) to lattice expansion is  $7 \times 10^{-4}$   $\mu\text{ohm-cm}$  for such deuteron irradiation. Use of the empirical defect concentrations then gives a value for the resistivity of 1% of Frenkel defects as 2.1 to 5.6  $\mu\text{ohm-cm}$ .

Thermal recovery of the expansion in the temperature range 10–302°K was measured. It was strikingly similar to the recovery of electrical resistivity changes produced by deuteron irradiation. About 55% of the recovery occurred in a range below 42°K and the recovery was essentially complete at 302°K. Whatever the activating mechanism may be in each stage of recovery, the observed recovery appears predominantly due to mutual annihilation of interstitials and vacancies.

## I. INTRODUCTION

COPPER is a particularly interesting crystal for radiation damage study.<sup>1,2</sup> Extensive theoretical calculation has been carried out for this metal; most bulk physical properties are well known; it is readily worked; and it is obtainable in relatively pure form. On the other hand, liquid-helium temperatures are required in order to prevent immediate thermal recovery of the damage produced by irradiation.<sup>3</sup> The

necessity of working at such low temperatures makes damage and annealing studies difficult.

In recent years a few helium-temperature investigations of irradiated copper have been carried out using electrons,<sup>4</sup> neutrons,<sup>5</sup> and deuterons.<sup>3</sup> While electron irradiation under suitable conditions is thought to produce the simplest disarrangement of the crystal lattice, the relative inefficiency of electron bombardment in producing atomic displacements has limited the variety of measurable effects and prevented the production of defect concentrations greater than chemical impurity concentrations. In nuclear reactor conditions are complicated by the incident-neutron energy spectrum, possible anisotropies in the neutron scattering cross section, gamma- and beta-ray flux, nuclear transmutations, and, most important, the large mean energy transmitted to the initially struck lattice atom. Cyclotron irradiations do not produce the simplest

\* Supported in part by the U. S. Atomic Energy Commission.

† Based upon a dissertation submitted by R. O. Simmons in partial fulfillment of the requirements for the Doctor of Philosophy degree at the University of Illinois.

<sup>1</sup> For a recent review of radiation effects in solids see F. Seitz and J. S. Koehler, in *Solid State Physics* (Academic Press, Inc., New York, 1956), Vol. 2, p. 305.

<sup>2</sup> Other recent surveys include J. W. Glen, *Advances in Physics* (Taylor and Francis, Ltd., London, 1955), Vol. 4, p. 381; G. H. Kinchin and R. S. Pease, *Repts. Progr. in Phys.* **18**, 1 (1955); A. H. Cottrell, *Metallurgical Reviews* **1**, 479 (1956); *Action des Rayonnements des Grande Energie sur les Solides* edited by Y. Cauchois (Gauthier-Villars, Paris, 1956); H. Brooks, *Annual Review of Nuclear Science* (Annual Reviews, Inc., Stanford, 1956), Vol. 6, p. 215; G. J. Dienes and G. H. Vineyard, *Radiation Effects in Solids* (Interscience Publishers, Inc., New York, 1957).

<sup>3</sup> Cooper, Koehler, and Marx, *Phys. Rev.* **97**, 599 (1955).

<sup>4</sup> Corbett, Denney, Fiske, and Walker, *Phys. Rev.* **104**, 851 (1956).

<sup>5</sup> Blewitt, Coltman, Klabunde, and Noggle, *J. Appl. Phys.* **28**, 639 (1957); Coltman, Blewitt, and Noggle, *Rev. Sci. Instr.* **28**, 375 (1956); Blewitt, Coltman, Holmes, and Noggle, in *Creep and Recovery* (American Society for Metals, Cleveland, 1957), p. 84.

type of damage, but experimental conditions are more strictly defined and direct access to the specimen being studied is possible during irradiation. In addition, such experiments produce a relatively high concentration of defects and hence a variety of effects which can be measured accurately.

Most previous experiments on irradiated copper at helium temperature have measured changes in electrical resistivity. Estimates of crystal defect concentration in copper made from electrical resistivity changes are unreliable at present since there is a wide theoretical disagreement about the resistivity per defect.<sup>6-11</sup> The situation may be better in the case of lattice expansion where the expansion per defect appears fairly well established.<sup>12-23</sup> Macroscopic volume changes which, of course, are closely related have been observed in deuteron-bombarded copper held near liquid-nitrogen temperature<sup>24</sup> and are currently being studied in this laboratory near helium temperature.<sup>25</sup> At the present time a unique physical model for radiation damage and its thermal recovery cannot be deduced from experimental results on copper and there is a clear need for further measurements of other properties.

No x-ray measurements of lattice expansion in irradiated copper have been reported. Investigations of changes in x-ray scattering of crystals resulting from nuclear reactor irradiation at room temperature and liquid-nitrogen temperature have been reported for several other materials and this technique holds promise of revealing information concerning the structural nature of the imperfections. The present

x-ray study of irradiated copper was designed to measure: (1) crystal lattice expansion as a function of integrated deuteron flux near liquid-helium temperature, (2) thermal recovery of the expansion upon subsequent warming, and (3) changes in x-ray scattering resulting from the damage.

## II. EXPERIMENTAL

The expected small size of the effect to be measured dictated a refined experimental technique, adapted to the awkward conditions peculiar to cyclotron irradiation experiments near helium temperature. In addition, a single-crystal foil specimen of high initial perfection and purity was desired. Hence, the experimental methods employed are described in some detail.

### 1. Method and Apparatus

Precise measurements of small lattice expansions were made using a rotating single-crystal back-reflection x-ray diffraction method.<sup>26</sup> From the Bragg law,

$$\Delta d/d = \Delta\lambda/\lambda - \Delta\theta \cot\theta,$$

where  $\theta$  is the Bragg angle,  $d$  the interplanar spacing, and  $\lambda$  the wavelength. For a closely constant spectral distribution  $\Delta\lambda \simeq 0$  and for large  $\theta$  the shift in angle,  $\Delta\theta$ , becomes a sensitive measure of lattice expansion. In the present experiment Co  $K\alpha_1$  radiation and a {400} reflection were used. At 10°K,  $\theta = 83^\circ 10'$  and  $\tan\theta = 8.345$ ; this choice of reflecting planes and characteristic radiation affords the highest sensitivity readily available for copper at low temperature.

A top view of the experimental arrangement is shown in Fig. 1. The linear dispersion at the film position,  $\Delta d/d$  per cm, was near  $7.7 \times 10^{-4}$ , lattice expansions producing horizontal displacements of the single Laue-Bragg line in direction  $e$ . During film exposures the rigid combination of x-ray source and film was rotated 1° by an electric motor about a vertical axis passing through the crystal in order to eliminate difficulties arising from small changes in crystal orientation or from macroscopic bending of the specimen foil. A slit collimator 0.010 in. wide and 0.080 in. high having maximum angular divergence  $0.42 \times 3.37^\circ$  was used on the x-ray tube. The recorded trace of the diffracted line was a circular arc about 2.5 cm high having a large radius of curvature. The width of the Laue-Bragg reflection for  $\theta > 80^\circ$  is principally due to the spectral width of the  $K\alpha_1$  emission line, even when a large collimator of rather generous angular divergence is used.<sup>27</sup> The combination of large collimator and low

<sup>6</sup> D. L. Dexter, Phys. Rev. **87**, 768 (1952); R. J. Potter and D. L. Dexter, Phys. Rev. **108**, 677 (1957).

<sup>7</sup> P. Jongenburger, Phys. Rev. **90**, 710 (1953); Appl. Sci. Research **B3**, 237 (1953); Nature (London) **175**, 545 (1955).

<sup>8</sup> F. Abeles, Compt. rend. **237**, 796 (1953); F. J. Blatt, Phys. Rev. **99**, 1708 (1955).

<sup>9</sup> Laura M. Roth, Bull. Am. Phys. Soc. Ser. II, **2**, 214 (1957); Ph.D. thesis, Radcliffe College, Cambridge, Massachusetts, 1956 (unpublished).

<sup>10</sup> A. W. Overhauser and R. L. Gorman, Phys. Rev. **102**, 676 (1956).

<sup>11</sup> W. A. Harrison (to be published).

<sup>12</sup> H. B. Huntington, Phys. Rev. **91**, 1092 (1953); Acta Met. **3**, 554 (1954).

<sup>13</sup> H. B. Huntington and F. Seitz, Phys. Rev. **61**, 315 (1942).

<sup>14</sup> L. Tewordt, Phys. Rev. **109**, 61 (1958).

<sup>15</sup> G. J. Dienes, Phys. Rev. **86**, 228 (1952).

<sup>16</sup> P. H. Miller, Jr., and B. R. Russel, J. Appl. Phys. **24**, 1248 (1953).

<sup>17</sup> J. Teltow, Ann. Physik **12**, 111 (1953).

<sup>18</sup> J. D. Eshelby, J. Appl. Phys. **24**, 1249 (1953); **25**, 255 (1954); *Solid State Physics* (Academic Press, Inc., New York, 1956), Vol. **3**, p. 79.

<sup>19</sup> F. Seitz, Revs. Modern Phys. **18**, 384 (1946).

<sup>20</sup> K. Huang, Proc. Roy. Soc. (London) **A190**, 102 (1947).

<sup>21</sup> C. W. Tucker, Jr., and J. B. Sampson, Acta Met. **2**, 433 (1954).

<sup>22</sup> W. Cochran, Acta Cryst. **9**, 259 (1956); W. Cochran and G. Kartha, Acta Cryst. **9**, 941, 944 (1956).

<sup>23</sup> J. B. Sampson and C. W. Tucker, Jr., Phys. Rev. **105**, 1117 (1957).

<sup>24</sup> W. R. McDonnell and H. A. Kierstead, Phys. Rev. **93**, 247 (1954); **98**, 1870 (1955); H. A. Kierstead, *ibid.* **98**, 245 (1955).

<sup>25</sup> R. W. Vook and C. A. Wert (to be published). Preliminary results of this work appear in reference 1, p. 405.

<sup>26</sup> The method depends on developments originated by M. de Broglie, Compt. rend. **157**, 924 (1913), U. Dehlinger, Z. Krist. **65**, 615 (1927), and H. Braekken, Kgl. Norske Videnskab. Selskabs, Forth. **1**, 192 (1929). The authors are indebted to Professor T. A. Read for showing them an unpublished Ph.D. thesis by D. J. Murphy, Columbia University, New York, 1952, in which a related method is employed.

<sup>27</sup> H. Ekstein and S. Siegel, Acta Cryst. **2**, 99 (1949).

crystal temperature permitted a film exposure time <20 minutes. Therefore, fogging of the film by the background radioactivity near the cyclotron and the influence of temperature variations during exposures taken in the recovery study were minimized.

The asymmetry in tube and film placement was chosen to maximize measuring sensitivity (by increasing specimen-to-film distance) and minimize exposure time (by reducing tube-focus to film distance). The particular dimensions were adopted after an extensive set of experimental trials; "defocusing" due to differing distances of tube focus and film from the crystal was found to be slight. Further, the mechanical rigidity of the arrangement was improved considerably by placing the heavy x-ray tube close to the center of rotation.

The crystal was maintained at low temperature in vacuum by attachment to the specimen tail of a helium cryostat of special design.<sup>28</sup> All other parts of the diffraction apparatus were in air at room temperature. The apparatus had good mechanical rigidity; the recorded position of the lowest temperature Laue-Bragg line was found to be independent of any previous temperature cycle of the specimen, mechanical shocks, or gross movements of the entire apparatus and cryostat. The apparatus included precise adjustments for putting the axis of rotation in the plane of the specimen and making the intended plane of incident and diffracted x-ray beams contain the crystal <100> direction.

The profile of the crystal reflection curve for the  $K\alpha$  doublet was obtained using a scintillation counter detector of 2.2-cm diameter aperture. Point by point measurements were made using a modified fixed-count method. Angular positions were set using a vernier accurate to 0.5' of arc. A single-channel pulse-height

FIG. 1. Schematic horizontal section of apparatus. The x-ray tube, collimator, and film are rigidly connected and rotate about vertical axis "a" passing through the specimen crystal.  $d$ =deuteron path,  $c$ =deuteron collimators,  $v$ =cryostat vacuum jacket,  $r$ =80°K radiation shield also serves as Faraday cup to measure integrated deuteron flux,  $p$ - $p$  defines plane of specimen and dummy foils,  $b$ =block at <5°K,  $t$ =trapdoor,  $m$ =0.2-mm thick Mylar polyester film window,  $sc$ =scintillation counter position,  $f$ =film cassette with provision for accurate film fiducial marks,  $e$ =measuring direction,  $x$ =x-ray tube and collimator,  $w$ =0.013 mm thick copper window.

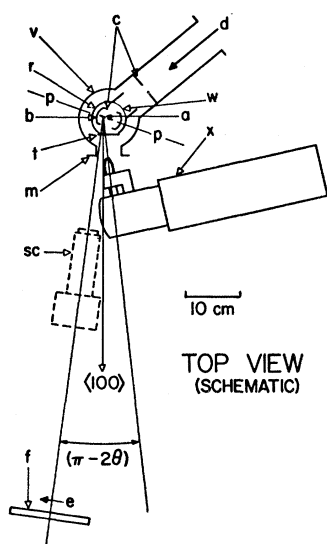

<sup>28</sup> D. E. Mapother and F. E. L. Witt, Rev. Sci. Instr. 26, 843 (1955). The mechanical design is essentially the same as described in this paper but additional precautions have been taken during cyclotron irradiation and subsequent recovery studies as described in the text.

analyzer separated the x-ray quanta counter pulses from the photomultiplier tube noise and higher energy pulses from cyclotron radioactivity.

All measurements, with the exception of preliminary thermal-expansion studies, were made with the cryostat attached to the target chamber of the Illinois cyclotron.<sup>29</sup> The cryostat and cyclotron vacuums were separated by a 0.025-mm thick Duralumin diaphragm which effectively excluded cyclotron oil and, most important, greatly reduced adsorption of gas from the cyclotron arc on the cryostat. In previous experiments<sup>3</sup> the evolution of such gas had led to a large and rapid temperature rise of the specimens during annealing following irradiation. A high-speed diffusion pumping system was incorporated in the cryostat. The integrated deuteron flux was calculated to an estimated accuracy of 4% from the known area of the grounded collimator and the total accumulated charge measured by an electronic current integrator.<sup>30</sup>

Accurate alignment of the specimen in the cyclotron beam is critical in this type of experiment where the specimen height is comparable to the half-width of the vertical intensity profile of the deuteron beam. Accordingly the entire cryostat and x-ray apparatus were mounted on a telescoping stand which could be driven up or down during operation of the cyclotron. A bellows provided the necessary flexible connection to the cyclotron target chamber. This equipment allowed the specimen to be set precisely in optimum position in the beam.

## 2. Error Analysis

The accuracy required in determining the instrumental constants can be analyzed by putting  $\Delta d/d = \xi = \Delta\theta \cot\theta$ . For small angular changes  $2\Delta\theta = x/l$ , where  $x$  measures the change in position of the Laue-Bragg reflection on the film and  $l$  is the specimen-to-film distance. Then the relative error in determining the lattice expansion is

$$\delta\xi/\xi = (2l\xi \tan\theta)^{-1}\delta x + l^{-1}\delta l + \csc\theta \sec\theta\delta\theta.$$

For the present apparatus this becomes

$$\delta\xi/\xi = (7.6 \times 10^{-5}/\text{mm})\xi^{-1}\delta x + (1.3 \times 10^{-3}/\text{mm})\delta l + 8.5\delta\theta.$$

The value of  $\theta$  can be inferred accurately from known thermal-expansion and room-temperature lattice-parameter values, while  $l$  can be measured easily to better than 1 mm. Hence  $\delta l$  and  $\delta\theta$  errors contribute at most a residual 1% relative error, independent of the expansion. Film shrinkage effects due to processing were appropriately corrected using measurements on a known array of fiducial marks.

<sup>29</sup> P. G. Kruger *et al.*, Rev. Sci. Instr. 15, 333 (1944). The cryostat and diffraction apparatus were located at position B of Fig. 5 of this paper.

<sup>30</sup> A modified version of a device described by H. T. Gittings, Jr., Rev. Sci. Instr. 20, 325 (1949).

The subjective errors in measuring line position are mostly random. A systematic one, *viz.*, measuring to a region of maximum blackening *versus* measuring to the mean blackening, was negligible since only small increments  $x$  were measured and all lines had the same appearance. Random errors in observing the line position can be evaluated in several ways. The distance  $x$  was measured using an X cross hair with low magnification on the cursor of a vernier film reader graduated directly to 0.05 mm. Repeated readings by the same observer and by different observers on the same film were examined for consistency. For any given film the mean absolute deviation of individual readings from the mean for a single observer was less than 0.03 mm, while the mean values for different observers varied by an average 0.05 mm. It is concluded that a reasonable value for  $\delta x$  is 0.06 mm, which corresponds to an expansion  $\xi = 5 \times 10^{-6}$ .

Several systematic errors are very small because  $\theta$  is near  $90^\circ$ . These include eccentric placement of the specimen and of the incident x-ray beam relative to the axis of rotation, finite specimen height, and absorption in the specimen. Those systematic errors which do not vanish at  $\theta = 90^\circ$ , such as uncertainty in the wavelength standard and refraction in the specimen, are unimportant because only small changes in  $\theta$  were measured.

Any rotation of the specimen crystal about an axis perpendicular to the  $\langle 100 \rangle$  direction used will produce a displacement of the diffracted line perpendicular to the measuring direction, because the collimator permits vertical divergence of rays from the source (see Fig. 1). Displacements of this type were observed but were found to be sufficiently small so that resulting shifts in the measuring direction could be neglected.

The problem of temperature measurement is localized at the specimen. All other parts of the diffraction apparatus are at room temperature, and normal variations in room temperature produce negligible dimensional changes in the apparatus. Variations in lattice parameter due to specimen temperature changes are negligible at low temperatures because even at  $30^\circ\text{K}$  the linear thermal-expansion coefficient is less than  $10^{-6}$  per degree. Recovery studies following bombardment were carried to higher temperatures and knowledge of specimen temperature and thermal expansion is required in order to allow separation of the dilation due to the recovery of the damage from the lattice expansion due to heating; the type of cryostat used does not permit pulse annealing with measurements at a fixed reference temperature. The same technique was employed for making thermal-expansion measurements and for recovery studies. A detailed report of the thermal-expansion measurements has appeared elsewhere.<sup>31</sup> Film exposures of 20 minutes were made (with  $1^\circ$  crystal rotation) as the specimen warmed continuously following exhaustion of the liquid helium from

the cryostat. The temperature assigned to each exposure was the temperature of the crystal at the known time the intensity maximum was registering on the film. The resulting temperature errors are all small because as the temperature, and hence the thermal-expansion coefficient, increased the temperature increment during measurement decreased. The largest error of this type corresponded to a lattice expansion of only  $1 \times 10^{-6}$ . The influence of temperature gradients in the specimen is believed to be negligible because of the high thermal conductivity of the material.

From the above analysis it is believed that the total error in any single lattice-expansion measurement is less than  $1 \times 10^{-5}$ .

### 3. Crystal Preparation and Mounting

The high-purity single-crystal copper foil used in this investigation was prepared by secondary recrystallization of heavily cold-rolled sheet possessing a special deformation texture. This method was chosen in preference to others because it was desired that the resulting very thin crystal be undeformed and of a predictable orientation.

The starting material was American Smelting and Refining Company continuously cast copper rod.<sup>32</sup> A rectangular ingot was cast in vacuum by solidification of a melt from one end. The high-purity end of the ingot which solidified first was treated to reduce the grain size below 0.1 mm. A final heavy reduction of 98% by cold rolling then produced sheet of the desired 0.089 mm thickness and deformation texture.<sup>33</sup> Specimen foils were cut out of sheet material prepared in this manner and were clamped at one end between blocks of A. S. and R. copper held tightly together by an A. S. and R. copper screw. This assembly was then immediately placed in a vacuum furnace for the final heat treatment. Continuous slow heating at  $10^\circ/\text{hour}$  in vacuum to a final temperature  $950^\circ\text{C}$  then produced in some cases very large crystals of suitable orientation at the free end of the foil. The heavy clamp permitted handling of the very easily damaged foils. Excellent heat conduction from foil to clamp, which was necessary to prevent overheating during bombardment, was obtained since a substantial area of metal to metal contact developed by sintering during the final high temperature treatment. A separate foil of the same material, subjected to the identical cycle of deformation and heat treatment, served to monitor the purity of the final crystal. The residual resistivity of the relevant monitor foil was  $5.4 \times 10^{-9}$  ohm-cm.

<sup>32</sup> Smart, Smith, and Phillips, *Trans. Am. Inst. Mining Met. Engrs.* **143**, 272 (1941). This material has a residual resistivity  $< 1.3 \times 10^{-9}$  ohm-cm, a stated purity of about 99.999%, and is quite coarse-grained.

<sup>33</sup> Heating this sheet to above  $300^\circ\text{C}$  for a suitable time produces polycrystalline cube texture sheet by recrystallization. This cubically aligned copper is the material in which very large "secondary" grains of highly preferred orientation may grow. See, for example, M. L. Kronberg and F. H. Wilson, *Trans. Am. Inst. Mining Met. Engrs.* **185**, 501 (1949).

<sup>31</sup> R. O. Simmons and R. W. Balluffi, *Phys. Rev.* **108**, 278 (1957).

Crystal perfection of similar large crystal sheets produced by this method was studied by using an x-ray monochromator technique.<sup>34-36</sup> These measurements indicated that the material had a dislocation density of order  $\leq 1 \times 10^7/\text{cm}^2$ , characteristic of well-annealed high-purity recrystallized copper.

The angle between the normal to the (400) planes whose interplanar spacing was studied and the direction of the incident deuterons was about  $49^\circ$ , and the deuteron path lay only approximately in the plane defined by  $\langle 100 \rangle$  and  $\langle 110 \rangle$  directions. Hence the incident deuteron path was inclined about  $5^\circ$  to the close-packed  $\langle 110 \rangle$  direction. This condition is believed to be a representative choice in view of possible small anisotropic effects during bombardment.

The clamp holding the foil was screwed to the upper inside face of a heavy hollow OFHC copper block (hereafter called block) which was attached to the specimen tail of the cryostat by screws and General Electric 7031 adhesive as shown in Fig. 2. The crystal under study occupied the extreme end of the specimen foil for 3.5 mm. Between the crystal and the clamp, small crystals of 0.1-mm diameter and less were present. The x-rays were incident on a 2.5-mm high by 1.0-mm wide region centered on the extreme tip. Thus, the boundary between irradiated and unirradiated regions

of the foil lay in the fine-grained region well separated from the crystal being studied.

With this type of mounting there was a question whether the rigid clamp would restrain the irradiation-induced lattice expansion at the region of interest near the foil extremity. A separate study was therefore carried out to determine the constraining effect of the clamp. Two large scale models of the irradiated part of the specimen foil, in which all dimensions were scaled up by a factor of twelve, were prepared of copper and one end of each soldered to the sides of a brass cylinder. One model was flat and the other had an initial curvature in order to test for buckling effects. Strain gauges<sup>37</sup> were glued to the model foil ends and the brass cylinder was then compressed longitudinally, thereby producing a compressive strain in the base of the model foils. This procedure approximated the restraint experienced by the actual specimen. For applied strains  $> 6 \times 10^{-4}$  at the base of the foil, strains at the tips never exceeded  $2 \times 10^{-6}$ . It thus appears certain that the region of the irradiated crystal studied by x-rays was essentially unconstrained by the clamp which supported and cooled the foil. Considerations using elasticity theory also support this conclusion.

#### 4. Temperature Measurement

The actual crystal foil was, of course, much too delicate to allow direct temperature measurements to be made on it. Such measurements were therefore made using a dummy of identical dimensions and characteristics with a fine copper-constantan thermocouple spot welded at the free end. The thermocouple leads were 0.10-mm diameter copper and 0.25-mm diameter constantan and a considerable lead length was coiled around the inside of the cold block cavity in order to minimize errors due to heat conduction through the leads. The specimen and dummy foils received essentially identical exposures to the deuteron beam which tends to fan out horizontally as it leaves the cyclotron target chamber.

The thermocouple assembly was first annealed and was then calibrated against the block resistance thermometer in final position in the block by enclosing the entire block assembly within an isothermal copper container suspended in a conventional glass helium cryostat. The reference thermometer was a platinum resistance thermometer calibrated by the National Bureau of Standards down to  $10^\circ\text{K}$ . Between  $4.2$  and  $10^\circ\text{K}$  an interpolation method was used. These calibrations are believed to be accurate to 0.1 of a degree above  $7^\circ\text{K}$ . Particular care was taken to keep the thermocouple lead wires undeformed and to approximate the thermal gradients expected in the bombardment cryostat.

The average deuteron beam current of  $0.053 \mu\text{a}/\text{cm}^2$  raised the dummy temperature to the vicinity of  $10^\circ\text{K}$ .

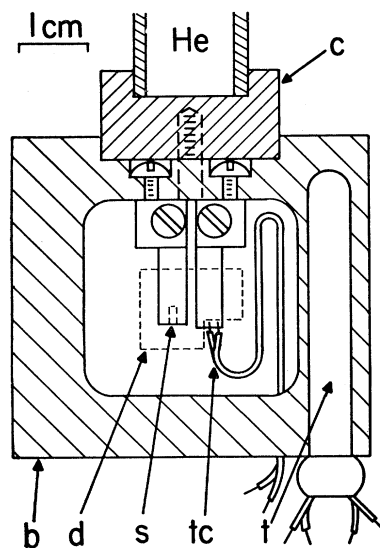

FIG. 2. Vertical section of specimen block assembly.  $c$  = tail of cryostat,  $b$  = OFHC copper block,  $d$  = cross section of deuteron beam,  $s$  = region on specimen crystal studied by x-rays,  $tc$  = dummy foil thermocouple,  $t$  = platinum resistance thermometer. The block has front and back faceplates as thermal radiation shielding for the specimen; the deuteron and x-ray ports subtend only about  $\pi/3$  steradian.

<sup>34</sup> Lambot, Vassamillet, and Dejea, *Acta Met.* **1**, 711 (1953); *Acta Metallurgica* **3**, 150 (1955).

<sup>35</sup> T. S. Noggle and J. S. Koehler, *Acta Met.* **3**, 260 (1955).

<sup>36</sup> The authors are indebted to Dr. G. S. Baker for taking these photographs.

<sup>37</sup> Baldwin-Lima-Hamilton Company SR-4 Type A-7.

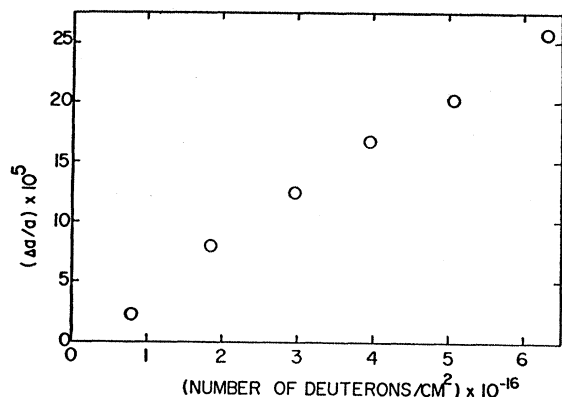

FIG. 3. Crystal lattice expansion under deuteron irradiation near 10°K. Changes in (400) interplanar spacing of single-crystal copper for incident deuteron energy near 7 Mev.

For a constant value of cyclotron current the dummy temperature gradually rose during the course of the entire irradiation. This rise is attributed to a steady decrease of thermal conductivity of the irradiated copper. The cyclotron current was limited so that the dummy temperature never exceeded 12.5°K during irradiation.

### III. RESULTS

#### 1. Lattice Expansion and x-ray Line Broadening

The first quantity of interest is the change of lattice parameter,  $a$ , as a function of irradiation near 10°K. From Fig. 3,  $\Delta a/a = (4.1 \pm 0.2) \times 10^{-21}$  per deuteron/cm<sup>2</sup>, taken from the slope of a straight line drawn through the experimental points. This value applies to a deuteron energy of 7 Mev since the measurements of lattice expansion were made on the foil face from which the deuterons emerged.<sup>38</sup> Thermal recovery data for temperatures below 90°K, taken during continuous warming and corrected for thermal expansion,<sup>31</sup> are shown in Fig. 4. The warmup rate was

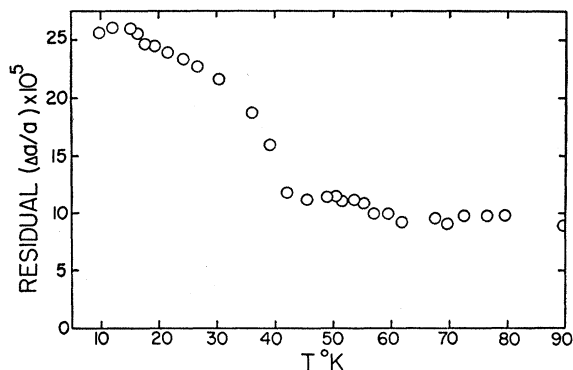

FIG. 4. Thermal recovery of irradiation-induced lattice expansion.

<sup>38</sup> The deuteron energy is degraded about 800 kev from an original 12 Mev by the Dural and copper windows before striking the inclined specimen foil.

an average 4 degrees per hour in the range 10 to 50°K and less than 3 degrees per hour above 50°K. The rate was variable, having a maximum at about 30°K, since it represented the natural warmup of the cryostat after the liquid helium was exhausted, as complicated by the release of adsorbed gas. Two further recovery points at maximum annealing temperatures of 227 and 302°K were measured, with the specimen again cooled each time to below 10°K where thermal-expansion corrections were unnecessary. At 227°K, 25% of the initial lattice expansion remained while at 302°K only 3% (or  $\Delta a/a = 9 \times 10^{-6}$  which is about the estimated error) remained.

The appearance of the Co  $K\alpha_1(400)$  line below 10°K as a function of irradiation and annealing is shown in Fig. 5 by typical microphotometer records of films. The intensity units are arbitrary. No broadening was detectable; the half-width at half-maximum intensity is constant within the measurement error of 2%.

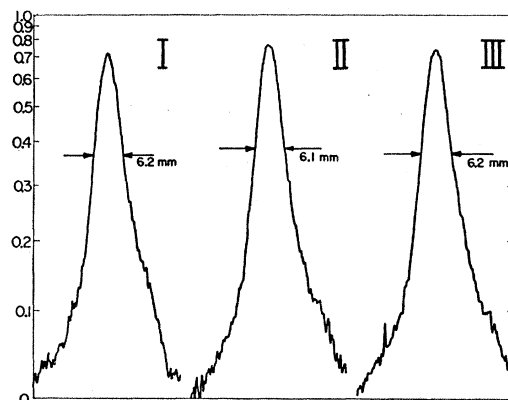

FIG. 5. Diffraction line width on film. Typical microphotometer records of films taken below 10°K before irradiation (I), after irradiation (II), and after irradiation and annealing at 302°K (III). No apparent line broadening is produced by an irradiation of  $6.3 \times 10^{16}$  deuterons/cm<sup>2</sup>.

Spectral width of the x-ray emission line accounts for about 65% of the observed line width.

#### 2. Inhomogeneity of Damage

In the present experiment it was expected that a slight macroscopic bellying of the specimen would occur as a result of the inhomogeneity of damage through the foil thickness.<sup>39</sup> Several x-ray effects were found which gave clear evidence that such bending did occur. Displacement and lengthening of the Laue-Bragg reflection perpendicular to the measuring direction were observed where the final displacement corresponded to an inclination of the crystal tip by 18' of arc and the final lengthening amounted to 17%. Independent substantiation of the bellying of the specimen foil as a

<sup>39</sup> A previous direct measurement was made in alpha-particle bombarded germanium by W. H. Brattain and G. L. Pearson, Phys. Rev. 80, 846 (1950).

result of irradiation was given by an 18% broadening of the reflection curve for the  $K\alpha$  doublet taken with the diffractometer below 10°K (Fig. 6). The angular measure  $\Phi$  represents the crystal orientation relative to the incident x-ray beam. Macroscopic bending contributed to broadening of the diffractometer profile because of the finite width of the x-ray beam incident on the specimen and the large counter aperture. The areas under the reflection curves have been normalized for comparison.

The radius of curvature,  $R$ , of the bellied foil may be calculated from these measurements. The inclination of the crystal tip and effective length of foil irradiated give  $R=114\pm 20$  cm. The width of the x-ray beam striking the crystal was 0.10 cm so that from the observed profile broadening of  $3.7'$  of arc,  $R=93\pm 10$  cm. Further, the profile broadening and film-line vertical

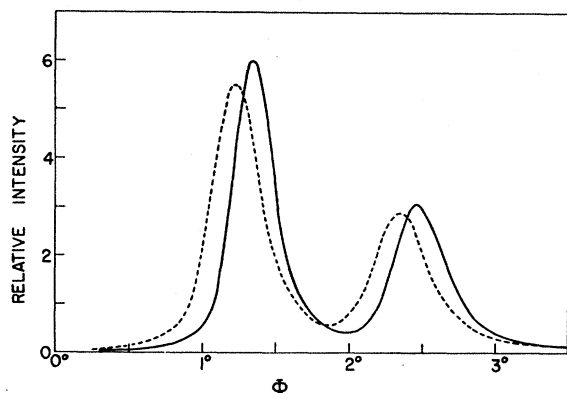

FIG. 6. Before and after irradiation. The diffractometer profile of the (400) Co  $K\alpha$  doublet near 10°K. Initial profile (solid line); final profile (dashed line). Here  $\Phi = \theta - \theta_0$ , where  $\theta$  is the Bragg angle (about 83°) and  $\theta_0$  is an arbitrary reference angle. The profile shows 18% broadening due to macroscopic bending of the specimen crystal. The bending agrees with that predicted by displacement-theory calculations of inhomogeneity of damage through the thickness of the crystal.

lengthening were the same on a percentage basis. The absence of line broadening on the films showed, in addition, that the x-ray measurement was made in a small homogeneously damaged volume adjacent to the specimen surface, as desired.

#### IV. DISCUSSION

##### 1. Bombardment Expansion

It appears that temperatures near 10°K are adequately low to suppress thermal recovery of the defects produced initially in copper. Variations in bombardment temperature of a few degrees may possibly have a small effect on the defect pattern for deuteron irradiation,<sup>3</sup> but apparently do not for electron irradiation.<sup>4</sup> No recovery of irradiation effects is observed if the copper is maintained below 10°K for an extended time, and thermal recovery does not begin until the material is warmed to about 15°K. Presence of the process termed

“radiation annealing,” as indicated by a curvature of the bombardment curve, is not detectable within the accuracy of the present experiment. The experimental accuracy of a single point in Fig. 3 is about  $1 \times 10^{-6}$ , and all measurements lie within this value for either a suitable straight line or a line of curvature similar to that observed in electrical resistivity experiments.<sup>3</sup>

The possibility of anisotropy of the expansion is not excluded by this experiment, which measured changes in (400) interplanar spacing only. It is considered likely that this effect would be small for cubic metals.

Various possible models for the defects produced by irradiation have different contributions to electrical resistivity changes and lattice expansions, and an experimental value for  $\Delta\rho/(\Delta a/a)$  is therefore of interest. Electrical resistivity changes during similar bombardment have been measured on 0.13-mm diameter copper wires of somewhat lower purity.<sup>3</sup> The measured resistivity change was  $2.1 \times 10^{-24}$  ohm-cm per (deuteron/cm<sup>2</sup>) as taken from a suitable average slope of the bombardment curve extending to the integrated flux of the present experiment. Correcting for the inhomogeneity of the damage, one obtains 9.5 Mev as the equivalent deuteron energy. If deuterons of 7 Mev had been used the resistivity change would have been larger, viz.,  $\Delta\rho = 2.8 \times 10^{-24}$  ohm-cm per (deuteron/cm<sup>2</sup>). Therefore, for the type of defects produced by deuteron bombardment near 10°K,

$$\frac{\Delta\rho}{\Delta a/a} = 7 \times 10^{-4} \text{ ohm-cm,}$$

to about 20%. This experimental number is independent of any theoretical model but does depend on the  $E^{-1}$  dependence of damage on deuteron energy  $E$  which appears to be verified in this work.

##### 2. Thermal Recovery of Expansion

The entire course of the thermal recovery of the lattice expansion is shown in Fig. 7. In the narrow temperature range 15–42°K (Stage I) about 55% of the

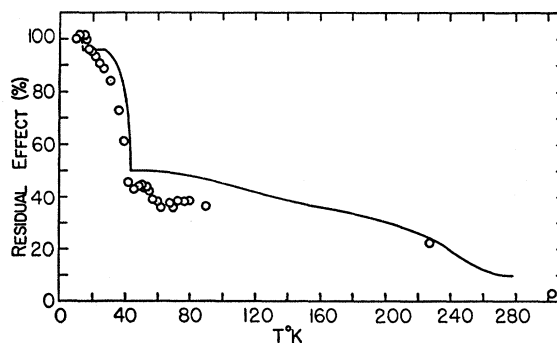

FIG. 7. Thermal recovery of deuteron damage in copper.  $\circ$  The present lattice expansion measurements; — electrical resistivity (Cooper *et al.*,<sup>3</sup> Run II; --- indicates the effect of an initial one-minute temperature pulse to near 30°K).

residual expansion annealed out. Between 42 and 227°K (Stage II) a further 20% disappeared, and in the range 227–302°K (Stage III) the remaining amount essentially recovered. The diffraction line breadth remained unchanged during recovery. The apparent slight hump in the thermal-recovery curve between the bombardment temperature and 20°K, while probably lying within experimental error, is reminiscent of the initial behavior of tempering curves for nuclear-reactor induced expansion of artificial graphite.<sup>40</sup>

Recovery of electrical resistivity changes measured under similar conditions<sup>3</sup> is strikingly similar to the recovery of lattice expansion. The results indicate that the ratio  $\Delta\rho/(\Delta a/a)$  is approximately constant throughout all stages of deuteron damage and thermal recovery. Differences in behavior in Stage I can be at least partly ascribed to the five times more rapid warmup rate during the resistivity measurements.

Some justification is required for the present method of correcting thermal-recovery data after irradiation using the thermal expansion of the well-annealed material. While the introduction of localized static defects undoubtedly changes somewhat the frequency distribution of lattice vibrations,<sup>41–43</sup> the evidence on actual crystals as to the nature and magnitude of the change is fragmentary and inconclusive. Some changes in the temperature dependence of electrical resistivity have been reported for copper bombarded and copper cold worked at liquid-nitrogen temperature,<sup>44</sup> but other work indicates that only very small changes in the temperature-dependent part of the resistivity of copper remain after Stage I recovery, for a deuteron bombardment comparable to the present one.<sup>45,46</sup> It should be noted that thermal corrections to the expansion become appreciable only *after* Stage I.

Earlier measurements on deuteron-irradiated copper in the range 120–290°K indicate that  $U/\Delta\rho$  is about 1.7 cal/gram per  $\mu\text{ohm-cm}$ , where  $U$  is the stored energy released upon warming.<sup>47</sup> For deuteron bombardment, it appears therefore that  $U/(\Delta a/a) \sim 10^3$  cal/gram. On the other hand, neutron-irradiated copper has been reported as having  $U/\Delta\rho < 0.8$  cal/gram per  $\mu\text{ohm-cm}$  for warming from 17 to 50°K.<sup>5</sup> It is to be noted that neutron damage may be qualitatively different from deuteron damage and also that the two experimental values are not necessarily in disagreement in view of the expected experimental accuracy of such difficult stored-energy measurements.

A detailed postulation of atomic processes to account for each thermal-recovery stage observed here appears inappropriate at present. The limited number of critical experimental measurements performed on copper does not yet permit assignment of a unique scheme. The tempering curve of the present experiment has qualitative significance but it is not useful in elucidating the kinetics of the annealing. If, as appears probable, a spectrum of activation energies is present for annealing (even in Stage I), the determination of frequency factors and orders of reaction would require a very detailed combination of measurements of a suitable physical property.<sup>48</sup>

### 3. X-Ray Scattering Effects

Treatments of the x-ray scattering by imperfect crystals have been presented elsewhere.<sup>20–23, 49–51</sup> Point defects, for example vacancies and interstitials, produce changes in scattering analogous to thermal effects. The positions of the Laue-Bragg intensity maxima are shifted but the maxima are not broadened; a reduction of intensity of certain maxima occurs and patches of diffuse scattering of characteristic shape appear.

Observed lattice expansions can be related quite directly to the number of defects if the solid is regarded as an isotropic elastic continuum containing spherically symmetric centers of dilatation. A mole fraction  $p$  of defects, randomly distributed, produces an apparent isotropic strain  $\Delta a/a = Ap$ .<sup>18–21</sup> The constant  $A = 4\pi c(1-\sigma)/v(1+\sigma)$ , where  $c$  is the strength of the centers of dilatation,  $\sigma$  is Poisson's ratio, and  $v$  is the atomic volume; here correction has been made for the effect of the free surface of a finite crystal.<sup>17,18,22,23</sup> The constant  $c$  must be evaluated from a detailed calculation of atomic positions around each type of defect. This has been done for interstitials and vacancies in copper.<sup>12–15</sup> Lattice distortions are more pronounced around an interstitial atom than around a vacant lattice site, hence an observed lattice expansion of a crystal containing Frenkel defects is primarily due to the interstitial atoms. For interstitials and vacancies in copper  $A$  has been estimated as 1.0 and  $-0.2$ , respectively.<sup>12,21</sup> These values, as absolute magnitudes, should probably be regarded as upper limits. The appropriate lower limit for cubically symmetric interstitials is about 0.5<sup>14</sup>; also it has been argued that there should be very little lattice relaxation around a vacancy,<sup>52</sup> which gives zero. If the defects are indeed clusters or are composed of small relatively amorphous regions, then the present investigation has determined the product  $pc$  for these

<sup>40</sup> Woods, Bupp, and Fletcher, *Proceedings of the International Conference on the Peaceful Uses of Atomic Energy, Geneva, 1955* (United Nations, New York, 1956), Paper No. P/746.

<sup>41</sup> E. W. Montroll and R. B. Potts, *Phys. Rev.* **100**, 525 (1955); **102**, 72 (1956).

<sup>42</sup> M. Lax, *Phys. Rev.* **94**, 1391 (1954).

<sup>43</sup> R. J. Elliott, *Phil. Mag.* **1**, 298 (1956).

<sup>44</sup> D. Bowen and G. W. Rodeback, *Acta Met.* **1**, 649 (1953).

<sup>45</sup> Magnuson, Palmer, and Koehler (to be published); *Bull. Am. Phys. Soc. Ser. II*, **2**, 356 (1957).

<sup>46</sup> A. W. Overhauser, *Phys. Rev.* **90**, 393 (1953).

<sup>47</sup> A. W. Overhauser, *Phys. Rev.* **94**, 1551 (1954).

<sup>48</sup> W. Primak, *Phys. Rev.* **100**, 1677 (1955).

<sup>49</sup> H. Ekstein, *Phys. Rev.* **68**, 120 (1945); W. H. Zachariasen, *Theory of X-ray Diffraction in Crystals* (John Wiley and Sons, Inc., New York, 1945).

<sup>50</sup> T. J. Matsubara, *J. Phys. Soc. Japan* **7**, 270 (1952).

<sup>51</sup> H. Kanzaki, *J. Phys. Chem. Solids* **2**, 24 (1957); *J. Phys. Chem. Solids* **2**, 107 (1957).

<sup>52</sup> A. Seeger and H. Bross, *Z. Physik* **145**, 161 (1956).



defects where  $p$  is the fraction of atoms involved in defects.

The apparently complete absence of line broadening in the present experiment indicates that the crystal defects produced by deuteron bombardment are indeed randomly distributed imperfections such as point centers of dilatation. In addition the diffractometer profiles (Fig. 6) show that the Cauchy-type shape of the crystal reflection curve is unchanged. A virtue of the present work is the exclusion of any spurious line-broadening effects due to specimen constraint.

The present x-ray study was restricted to a very small volume of reciprocal space around (4,0,0) because the primary purpose of this investigation was a precise measurement of lattice expansion under the most favorable conditions. No study of the diffuse x-ray scattering or the dependence of Laue-Bragg intensity upon the indices of reflection has yet been made. It has been predicted that observation of these effects in copper requires a higher concentration of defects than was obtained here.<sup>22</sup> Further information on the structural nature of the defects may come from such an extended x-ray investigation.<sup>53</sup>

#### 4. Inhomogeneity of Damage

The present experimental results involving the macroscopic bellying of the foil can be used to find the dependence of rate of damage on deuteron energy. On the assumption that the damage varies approximately linearly through the thin specimen, an elasticity calculation shows that the residual stress at the foil surface is very nearly zero, so that all portions of the foil have expanded freely. The thickness,  $t$ , and radius of curvature,  $R$ , of the bellied foil and the expansion of the convex (back) face,  $\Delta a/a$ , are known. Hence at the end of bombardment the front face has expanded only  $(1-f)$  as much as the back face, where  $f=t/[R(\Delta a/a)]=0.33\pm 0.05$ . From the effective sample thickness  $t/\cos 30^\circ \simeq 0.10$  mm and the known range-energy relations<sup>54</sup> the deuteron energy,  $E$ , at the back is  $0.61 \simeq (1-f)$  that at the front. Hence the damage rate varies inversely with  $E$  within about 15%.

For nonrelativistic Coulomb encounters, the probability of displacement of a lattice atom by a particle of energy  $E$  varies as  $E^{-1}$ .<sup>1</sup> Further, if the atoms are treated as rigid spheres, the number of (secondary) atoms displaced by the initially displaced lattice atom (or primary) is nearly independent of  $E$  for the changes in  $E$  present in this investigation. The result is not greatly changed by the presence of displacement spikes in the limited numbers estimated for cyclotron irradiation.<sup>55</sup>

The above results prove, therefore, that (1) the rate of damage varies inversely with  $E$ , as predicted by

present theories, and (2) the surface region of the foil where the lattice-expansion measurements were made was unconstrained. Taken together with earlier verification of the  $n_0 Z^2/M$  dependence of damage on the atomic number and mass of the lattice atoms,  $Z$  and  $M$ , and their density of packing,  $n_0$ , for the homologous systems Cu, Ag, and Au<sup>3</sup>, the present measurements show that the aspects of irradiation displacement theory and experiment which require closest scrutiny are the assumption of a simple displacement threshold,  $E_d$ , and the behavior of the higher energy primary displaced atoms. While present theory does give the correct functional dependence  $n_0 Z^2/ME$ , it apparently overestimates the number of atoms displaced.

#### 5. Foreign Atoms and Other Defects

The copper single crystal studied in this investigation had an estimated initial impurity concentration of  $(3 \text{ to } 4) \times 10^{-5}$ , calculated from residual resistivity together with a knowledge of probable impurities. From the x-ray monochromator measurements on the material studied in this investigation the concentration of dislocation sites is found to be less than  $10^{-8}$ . This value is small compared to the chemical impurity concentration and indicates that the influence here of dislocations in irradiation effects was extremely small. Their role in recovery phenomena requires further analysis.

Deuteron and neutron irradiation produce additional lattice impurity atoms by transmutation of nuclei. Further, cyclotron bombardments of an external target with deuterons also involve fast neutron bombardment from  $(d,n)$  reactions in the cyclotron dee and target chambers. These neutrons not only can produce additional transmutations but also may cause lattice damage of a type qualitatively different from that produced by deuterons.<sup>1,2,55</sup> It is believed from resistivity measurements made in this laboratory that these effects amount to approximately one percent of the damage under the particular conditions of the present experiment.

In the helium-temperature irradiation experiments performed to date, except for some preliminary work on dilute copper-base alloys,<sup>5</sup> the nature and number of impurities have been unknown, while the total number of impurities may have been comparable in some cases to the number of defects produced by bombardment (see the discussion at the end of Part V). The precise influence of impurities upon thermal recovery of radiation damage has not been fully determined, although it should be noted that a comparatively large change in impurity concentration does not necessarily have much effect. An example is the recovery of electrical resistivity in deuteron-irradiated copper of 0.9995 and higher purity; the gross features of recovery behavior are similar in specimens having impurity concentrations

<sup>53</sup> C. W. Tucker, Jr., and P. Senio, Phys. Rev. **99**, 1777 (1955).

<sup>54</sup> Aron, Hoffman, and Williams, University of California Radiation Laboratory Report UCRL-121, 1949 (unpublished).

<sup>55</sup> J. A. Brinkman, Am. J. Phys. **24**, 246 (1956).

differing by a factor of at least 40, for both helium<sup>3,45</sup> and nitrogen<sup>56,57</sup> temperature irradiations.

#### V. MODEL

Among the models that have been proposed for possible defects produced in metals under present conditions are (1) Frenkel defects with the interstitial having cubic symmetry, (2) multiple vacancies,<sup>55</sup> (3) the crowdion configuration for the interstitial,<sup>58</sup> (4) displacement spikes,<sup>55</sup> and (5) locked-in dislocation loops.<sup>59,1</sup> Theoretical estimates of the effects of Frenkel defects, (1), on lattice dilatation, x-ray scattering, electrical resistivity, and elastic constants of copper have been made. In addition their energies of formation and migration have been estimated. The other defects have not been treated in such detail; the crowdion would appear to be the best defined and susceptible of quantitative treatment.<sup>60</sup>

For concreteness, detailed analysis is made below for model (1) because well-defined theoretical estimates

of properties have been made for this model and quantitative comparisons can be drawn between theory and experiment. In addition the relative number of displacement spikes for this cyclotron irradiation is either small or zero. If, as appears likely, lattice expansion depends mostly on interstitials, the effect of multiple vacancies would be minimal. Possible dislocation loops are probably a marginal effect in the present experiment. It is worth noting that for defects (2) to (5) the effect per displaced atom is probably smaller than model (1) so that a given expansion or electrical resistivity change would require a higher concentration of displaced atoms. It is not known, however, at present whether the ratio  $\Delta\rho/(\Delta a/a)$  would necessarily be much different for these other defects.

On the assumption that the defects produced by irradiation are of Frenkel type,  $\Delta a/a = 0.3p$  to  $0.8p$  and  $p$  is therefore  $(5 \text{ to } 13) \times 10^{-21}$  per (deuteron/cm<sup>2</sup>). On the other hand, the simple theory of displacement predicts  $p = \bar{v}n = 5.8 \times 10^{-20}$  per 7-Mev deuteron/cm<sup>2</sup>, which is higher by a factor 4.5 to 12. The simple theory assumes a well-defined threshold energy  $E_d$  ( $\sim 25$  ev) for displacement of an atom in order to evaluate  $n$ , the number of primary displacements per incident particle.<sup>61</sup>

<sup>56</sup> Marx, Cooper, and Henderson, Phys. Rev. **88**, 106 (1952).

<sup>57</sup> J. E. Mercereau and R. O. Simmons (unpublished).

<sup>58</sup> W. M. Lomer and A. H. Cottrell, Phil. Mag. **46**, 711 (1955).

<sup>59</sup> F. Seitz, Phys. Rev. **98**, 1530 (1955).

<sup>60</sup> Reference 14 contains a treatment of the crowdion formation energy and lattice relaxation in copper.

<sup>61</sup> F. Seitz, Discussions Faraday Soc. **5**, 271 (1949).