

t = time between separation and previous separation. The decay constant determined for Pu^{245} corresponds to a half-life of 10.6 ± 0.4 hours. The decay curve of Pu^{245} , determined from the Am^{245} milkings, showed a constant half-life for a period of more than ten half-lives. The Pu^{245} half-life can be compared with 10.5 ± 0.5 hours obtained by Argonne¹⁷ and 12 ± 1 hours obtained by Los Alamos.¹⁶

The amount of Pu^{245} corresponds to an NRX pile capture cross-section of 2.1 ± 0.3 barns for Pu^{244} . This

value is a little higher than the value of 1.4 ± 0.5 barns obtained by Argonne in the new CP-5 pile.¹⁷

ACKNOWLEDGMENTS

The authors wish to thank the operators of the Materials Testing Reactor and the NRX reactor for irradiating the samples. We also wish to thank Mr. A. J. Frey of Atomic Energy of Canada, Ltd., for determining the concentrations of the plutonium for the specific activity measurements.

Excited States of $\text{S}^{34}\dagger^*$

G. S. STANFORD[†] AND G. F. PIEPER

Sloane Physics Laboratory, Yale University, New Haven, Connecticut

(Received March 5, 1956)

The mode of decay of the second excited state of S^{34} has been examined, using a "slow-fast" coincidence technique to examine the gamma rays in coincidence with the appropriate proton group from the reaction $\text{P}^{31}(\alpha, p)\text{S}^{34}$. By comparing the observed cascade to cross-over intensity ratio with that calculated from the Weisskopf lifetime relationships, the number of possible spin-parity combinations for the first and second excited states can be restricted. When the results of beta decay studies are taken into account, it can be inferred that the first two excited states of S^{34} are both $2+$. Spin $0+$ for the ground state is assumed.

New measurements of the energies of the low-lying excited states of S^{34} are reported. It is concluded that there are levels at 2.13 ± 0.02 , 3.33 ± 0.05 , 4.32 ± 0.08 , and 4.8 ± 0.1 Mev.

I. INTRODUCTION

PREVIOUS experiments¹⁻³ carried out in this laboratory have studied the decays of a number of excited states of Si^{30} , Mg^{26} , and Ne^{22} . In each case, the residual nucleus was obtained by means of an (α, p) reaction on the appropriate target. Each experiment consisted of selecting a particular excited state of the residual nucleus by selecting the proper proton group, and examining the energy spectrum of the gamma rays in coincidence with these protons. From such data it is possible to determine the mode of decay of an excited state: how much by cascade through other levels and how much by cross-over transitions. Such results are made meaningful by the theoretical lifetime relationships of Weisskopf,^{4,5} which give the probability per unit time of a gamma-ray transition of

given energy as a function of nuclear parameters and the multipole order of the radiation. The theoretical predictions are based on a single-particle model and are relatively crude, at times being in error by a factor of 100 or more; at the same time it can be pointed out that the relative transition probabilities can vary over a range of more than 10^{17} . Therefore, the relations are often useful in determining gamma-ray multipolarities.

The present paper reports the result of an investigation similar to the earlier ones concerning the second excited state of S^{34} , reached by means of the reaction $\text{P}^{31}(\alpha, p)\text{S}^{34}$. Mention is also made of those experimental techniques which have been improved since the earlier work.

II. EXPERIMENTAL METHODS

A. Target Preparation

The phosphorus targets were prepared by evaporating a solution of red phosphorus in ethyl alcohol, allowing the solute to deposit on a 0.0001-in. gold target backing at the bottom of a well one inch deep. The wall of the well was made of Teflon, which is not wet by alcohol, resulting in an even deposition of phosphorus on the gold.

The aluminum targets used for calibration consisted of aluminum foil of thickness ~ 0.2 mg/cm², fastened to a wire ring by means of indium solder.

[†] Part of a dissertation presented by G. S. Stanford to the faculty of the Graduate School of Yale University in partial fulfillment of the requirements for the degree of Doctor of Philosophy.

* This work was performed under the joint auspices of the Office of Naval Research and the U. S. Atomic Energy Commission. Reproduction in whole or in part is permitted for any purpose of the United States Government.

[†] Present address: Perkin-Elmer Corporation, Norwalk, Connecticut.

¹ Allen, May, and Rall, *Phys. Rev.* **84**, 1203 (1951).

² J. E. May and B. P. Foster, *Phys. Rev.* **90**, 243 (1953).

³ Foster, Stanford, and Lee, *Phys. Rev.* **93**, 1069 (1954).

⁴ V. F. Weisskopf, *Phys. Rev.* **83**, 1073 (1951).

⁵ J. M. Blatt and V. F. Weisskopf, *Theoretical Nuclear Physics* (John Wiley and Sons, Inc., New York, 1952).

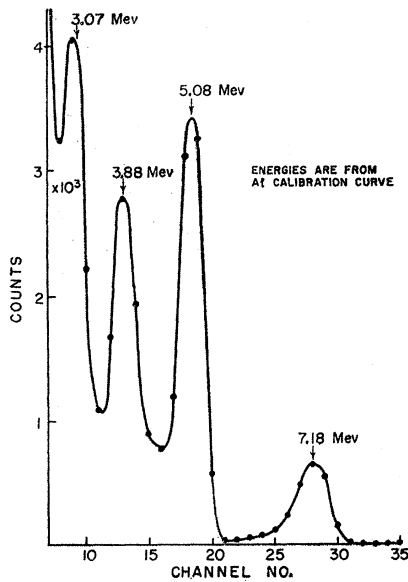

FIG. 1. Proton groups from $P^{31}(\alpha, p)S^{34}$. These data were obtained using the NaI(Tl) scintillation spectrometer. The proton group energies were obtained from calibration data based upon the $Al^{27}(\alpha, p)Si^{30}$ reaction.

B. Measurement of Excited-State Energies

The excitation energies of S^{34} were measured by several methods. One of these was the conventional determination of proton range in aluminum, using the reaction $P^{31}(\alpha, p)S^{34}$. The proton spectrum from the same reaction was also examined with a 1-mm thick NaI(Tl) detector mounted on a 6291 photomultiplier tube (see Fig. 3). The pulse-height distribution was

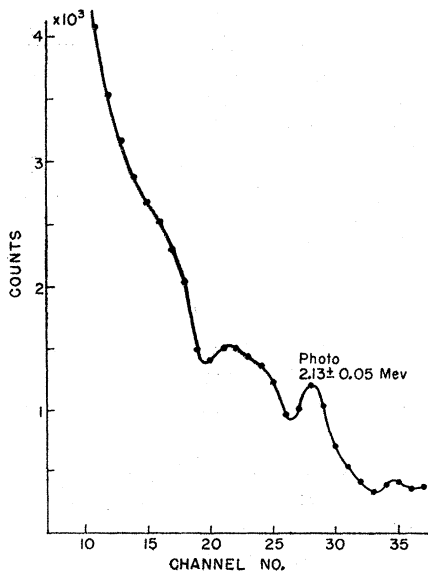

FIG. 2. Low-energy gamma-ray spectrum from the alpha-particle bombardment of P^{31} .

determined with a 40-channel pulse-height analyzer.⁶ A typical spectrum is shown in Fig. 1. For the energy calibration of such spectra, the phosphorus target was replaced by an aluminum target and its proton spectrum was obtained under the same conditions. By using the known energy levels⁷ in Si^{30} , the energies of the proton groups were computed. When calibration curves of energy *vs* channel number were plotted, they were found to be linear within experimental error ($\sim 1\%$).

A determination of the energy of the first excited state of S^{34} resulted from observing the gamma rays from the α -particle bombardment of phosphorus, with a typical spectrum shown in Fig. 2. Detection of the gamma rays was by means of a NaI(Tl) crystal 1 inch in height by $1\frac{1}{2}$ inches in diameter. (See Fig. 3.) The crystal was mounted on a 6292 photomultiplier tube, which seems not to have been the best choice: it has recently been reported that this tube type suffers from a change of pulse height with counting rate.⁸ The

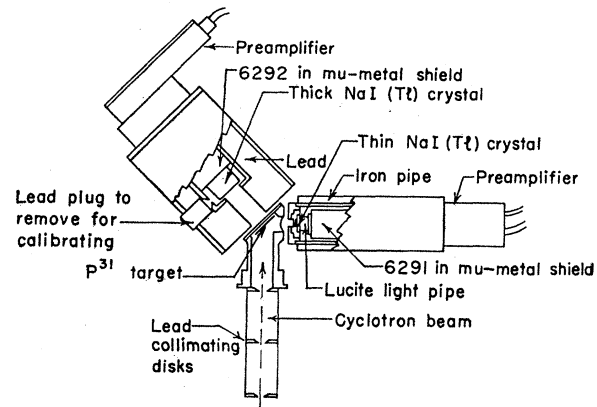

FIG. 3. Arrangement of scintillation detectors used in the coincidence experiments.

spectra as in Fig. 2, and the calibrating runs using the gamma rays from thorium-active deposit, were taken at approximately the same counting rates. Again the calibration curves were found to be linear. That the peak in Fig. 2 actually corresponded to the decay of the first excited state of S^{34} was established by a coincidence run with protons leading to this state (see below).

The coincidence experiment $P^{31}(\alpha, p\gamma)S^{34}$ was used for a determination of the energy of the second excited state of S^{34} . The experimental method will be discussed below. In the case of the first excited state, the dependence of pulse height on counting rate, mentioned above, made the (α, γ) reaction a more precise method for determining energy than the $(\alpha, p\gamma)$ reaction.⁹ But

⁶ E. J. Cook, Yale dissertation, 1954 (unpublished); E. J. Cook and G. F. Pieper, *Phys. Rev.* **98**, 1154 (1955).

⁷ P. M. Endt and J. C. Kluver, *Revs. Modern Phys.* **26**, 95 (1954).

⁸ Bell, Davis, and Bernstein, *Rev. Sci. Instr.* **26**, 726 (1955).

⁹ The (α, γ) runs were done with an α beam $\sim \frac{1}{4}$ of that used in the $(\alpha, p\gamma)$ runs. The pulse-height shift observed was an increase of $\sim 2\%$ for the greater beam current.

for the second excited state the photopeak for the transition to the ground state was not prominent in the (α, γ) spectrum, so that the coincidence spectrum, with allowance made for the pulse-height shift, was used. Calibration was as for the (α, γ) spectrum.

C. Coincidence Experiments

The experimental arrangement for the coincidence work is shown in Fig. 3, and in Fig. 4 is a block diagram of the electronic setup. This "slow-fast" system has been described elsewhere¹⁰; it makes feasible the inclusion of a continuous monitor for the accidental coincidences, highly desirable with a phase-grouped cyclotron beam. The spectra were obtained with the 40-channel analyzer,⁶ replacing the previously used moving-film technique.¹⁻³

With the single-channel analyzer set so as to select only those protons leading to the first excited state of S^{34} , the gamma-ray spectrum of Fig. 5 was obtained.

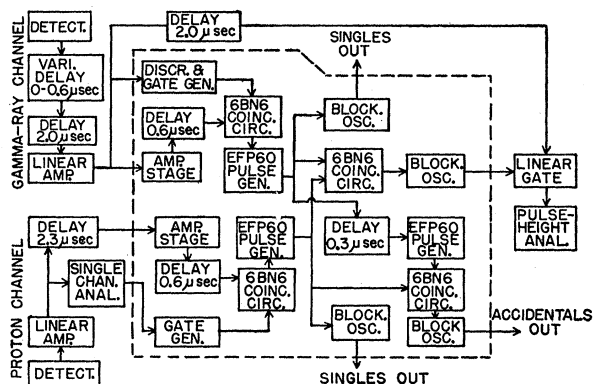

FIG. 4. Block diagram of slow-fast coincidence circuit.

The curve is the result of two consecutive 70-minute runs. For energy calibration, spectra of thorium-active gamma rays, of Na^{22} gamma rays, and of the (α, γ) reaction, were taken before and after each of the runs. This spectrum was obtained partly to test the operation of the equipment, and partly to look for evidence of a cascade through a possible excited state at ~ 0.8 Mev (see below). No such evidence is seen, although if the cascade were present but reduced in intensity by a factor of three or more it probably would not be evident.

Figure 5 shows a large peak at ~ 0.5 Mev. It is definitely in coincidence with the first excited state protons, since the background correction (see below) has been made. This peak is attributed to annihilation radiation from pairs produced in the lead surrounding the crystal by gamma rays from the first excited state.

¹⁰ G. S. Stanford and G. F. Pieper, Rev. Sci. Instr. 26, 847 (1955).

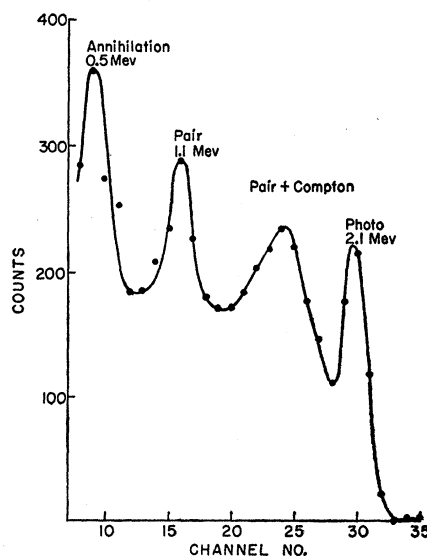

FIG. 5. Energy spectrum of gamma rays in coincidence with the proton group corresponding to the first excited state of S^{34} in the reaction $P^{31}(\alpha, \beta)S^{34}$. The correction for accidental coincidences has been made.

The other peaks in the spectrum are what would be expected from a single gamma ray.

The corresponding spectrum for the second excited state is shown in Fig. 6. For this state, three consecutive 90-minute runs were taken, calibrated as before. Figures 5 and 6 have been corrected¹⁰ for accidental-coincidence background by normalizing the (α, γ) spectrum to the number of accidental coincidences registered by the monitor, and subtracting the result

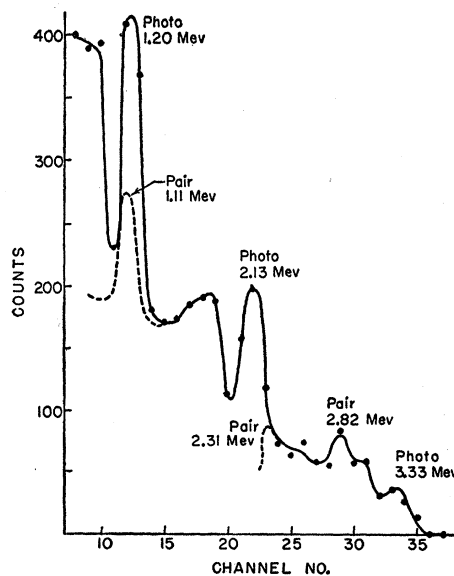

FIG. 6. Energy spectrum of gamma rays in coincidence with the proton group corresponding to the second excited state of S^{34} in the reaction $P^{31}(\alpha, \beta)S^{34}$. The correction for accidental coincidences has been made.

from the raw coincidence spectrum. In determining the energy of the cross-over gamma ray from Fig. 6, heaviest reliance was placed upon the first pair peak, appearing near channel 29. The contribution to the crossover peak due to "pileup" of the cascade gamma rays in the crystal was computed, and was found to be negligible.

III. ENERGY LEVELS IN S^{34}

A. Ground State Q of $P^{31}(\alpha, p)S^{34}$

By using weighted means of the more recent and relevant doublet measurements,¹¹ atomic mass values for use in computing the Q value of the reaction $P^{31}(\alpha, p)S^{34}$ can be obtained. By so doing, the Q value of 0.59 ± 0.05 Mev was calculated.

In the course of the present work, the Q value 0.7 ± 0.2 Mev has been obtained from the measurement of proton range in aluminum, and the value 0.7 ± 0.1 Mev by using a crystal proton detector, as described above.

B. Evidence Against Level at ~ 0.8 Mev

In the bombardment of natural sulfur, a weak proton group has been observed,¹² which was interpreted as possibly coming from $S^{33}(d, p)S^{34}$, corresponding to a level at ~ 0.8 Mev in S^{34} . It seems doubtful that this assignment is correct, for the following reasons.

(1) In the present work, it has failed to show in the $P^{31}(\alpha, p)S^{34}$ reaction, at any angle of observation. For 90° observation (see Fig. 1) an upper limit of $\sim 10\%$ of the ground state group can be set, unless the group is within 0.4 Mev of the ground state group. In an attempt to resolve it, spectra were obtained by putting an aluminum absorber between the target and the crystal, to permit only the higher energy protons to enter the crystal. Thus the small energy range of interest could be spread over the entire range of the 40-channel analyzer. No new peak was observed.

(2) No transitions to this state have been observed in the β decay of P^{34} ,¹³ or of Cl^{34} ,¹⁴⁻¹⁶ although this could merely indicate a forbidden transition.

(3) In the spectrum of gamma rays from the 2.1- and 3.3-Mev levels in S^{34} reported in this paper (see Figs. 5 and 6) and elsewhere,^{14,15,17} there is no evidence of a cascade gamma ray to a low-lying excited state, although this too could be due to selection rules.

(4) On the basis of the systematics of even-even nuclei in this region of the periodic table, such a low-lying first excited state is improbable.¹⁸

(5) The spin of the level at 2.1 Mev is 2, with even parity, and the decay of the next higher state is largely by cascade through this level (see below). If there were a lower-lying $2+$ level, the Weisskopf lifetime relations^{4,5} predict a greater probability of transition to this level than to the higher one. On the basis of the present coincidence work, then, it can definitely be said that if there is such a level, it is not $2+$. Only two nuclides with $A \leq 40$ are definitely known to have first excited states other than $2+$. These are O^{16} ,¹⁹ and Ca^{40} ,²⁰ Both have $0+$ first excited states; that this should be the case for doubly magic nuclei has been pointed out by Scharff-Goldhaber.¹⁸

In view of the foregoing, it will henceforth be assumed that the first excited state of S^{34} is the level at 2.1 Mev, and we will now consider its precise excitation energy.

C. Energy of the First Excited State of S^{34}

At the time this work was done, two values of the first excited state energy with precision ≤ 0.1 Mev were available.^{16,17} A value of 2.16 ± 0.08 Mev had been obtained from a study of the β^+ spectra of Cl^{34*} with a magnetic lens spectrometer,¹⁶ and a value of 2.10 ± 0.03 Mev from a scintillation spectrometer study¹⁷ of the gamma rays from Cl^{34*} . The present work yielded two values for this energy: 2.14 ± 0.03 Mev from the gamma-ray scintillation spectrum of $P^{31}(\alpha, \gamma)$, and 2.14 ± 0.04 Mev from the range measurements on $P^{31}(\alpha, p)S^{34}$. Two determinations were made by each method.

The agreement among the above values is good; the mean value, 2.13 ± 0.02 Mev, has been taken for the energy of the first excited state.

Since the completion of this work, a value of 2.129 ± 0.014 Mev has been obtained²¹ from the measurement of alpha particle groups from $Cl^{37}(p, \alpha)S^{34}$ using a Van de Graaff generator and a magnetic spectrometer. Our mean value is in good agreement with this more accurate determination.

TABLE I. Energy of second excited state of S^{34} .

Method	Value, Mev	Reference
β^+ spectrum of Cl^{34*} ; mag. lens spect.	3.31 ± 0.10	a
Gamma-ray scint. spectrum of Cl^{34*}	3.26 ± 0.05	b
	3.22 ± 0.03	b
Gamma-ray coinc. spectrum of $P^{31}(\alpha, p\gamma)S^{34}$	3.33 ± 0.08	Present work
	3.38 ± 0.10	Present work
$P^{31}(\alpha, p)S^{34}$; range in aluminum	3.38 ± 0.10	Present work
$P^{31}(\alpha, p)S^{34}$; crystal detection, calibrated with $Al^{27}(\alpha, p)Si^{30}$	3.49 ± 0.08	Present work
Mean value	3.33 ± 0.05	

^a See reference 16.

^b See reference 17.

¹⁹ F. Ajzenberg and T. Lauritsen, *Revs. Modern Phys.* **27**, 77 (1955).

²⁰ Bent, Bonner, and McCreary, *Phys. Rev.* **98**, 1325 (1955).

²¹ Van Patter, Swann, Porter, and Mandeville, *Bull. Am. Phys. Soc. Ser. II*, **1**, 39 (1956).

¹¹ Duckworth, Hogg, and Pennington, *Revs. Modern Phys.* **26**, 463 (1954).

¹² P. W. Davison, *Phys. Rev.* **75**, 757 (1949).

¹³ E. Bleuler and W. Züti, *Helv. Phys. Acta* **19**, 137 (1946).

¹⁴ Ho Zah-Wei, *Phys. Rev.* **70**, 782 (1946).

¹⁵ L. Ruby and J. R. Richardson, *Phys. Rev.* **83**, 698 (1951).

¹⁶ D. Green and J. R. Richardson, *Phys. Rev.* **96**, 858(A) (1954); **101**, 776 (1956).

¹⁷ Harold K. Ticho, *Phys. Rev.* **84**, 847 (1951).

¹⁸ Gertrude Scharff-Goldhaber, *Phys. Rev.* **90**, 587 (1953).

D. Energy of the Second Excited State of S^{34}

The measurements of the second excited state energy are not in general as precise as for the first excited state, and there is not good agreement from one determination to another. Three values from the literature^{16,17} have stated precision ≤ 0.1 Mev. These appear in Table I, along with three new determinations. The average of these six values, 3.33 ± 0.05 Mev, will be assumed to be the excitation energy of the second excited state.

The value 3.26 Mev ascribed to reference 8 is obtained by adding the results from that paper (2.10 ± 0.03 and 1.16 ± 0.03 Mev) for the two lower energy gamma rays (see Fig. 7).

A comment on the two extreme values in Table I is perhaps in order. At the lower extreme is the 3.22-Mev value for γ_1 (see Fig. 7) of Ticho.¹⁷ He arrived at this result by locating the photopeak, calibrating his system with the 1.28-Mev gamma ray from Na^{22} , and assuming linearity. It is tempting to suggest the possibility that linearity did not hold for such a long extrapolation.

A possible explanation for the divergence of the last value in Table I does not readily present itself. It is not a question of extrapolation, since the relevant proton groups come where the calibration curve [from $Al^{27}(\alpha, p)Si^{30}$ —see the foregoing] is most reliable. Moreover the reported measurement is the average of four runs done on different days and under somewhat different conditions, with consistent results. This value therefore has its influence on the probable excitation energy of the second excited state, since no good reason has been found for excluding it.

E. Energy of the Third Excited State of S^{34}

No measurements of excited states of S^{34} higher than the second have been published since the 1936 natural-alpha work of Pollard and Brasefield,²² with the exception of the mention of a state at 3.9 Mev by Bleuler and Morinaga.²³ In the course of the present work some data pertaining to two more excited states have been collected.

Four scintillation runs on $P^{31}(\alpha, p)S^{34}$ (Fig. 1) give the third excited state as being 2.33 ± 0.10 Mev above the first excited state. Using 2.13 Mev for the latter, the excitation energy of the third excited state becomes 4.46 ± 0.10 Mev. From a measurement of range in aluminum at 90° observation, the value 4.24 ± 0.06 has emerged. A weighted mean of these two measurements is 4.32 ± 0.08 Mev. No evidence for a state at 3.9 Mev²³ was observed.

²² E. Pollard and C. J. Brasefield, Phys. Rev. **50**, 890 (1936).

²³ E. Bleuler and H. Morinaga, Phys. Rev. **99**, 658 (1955).

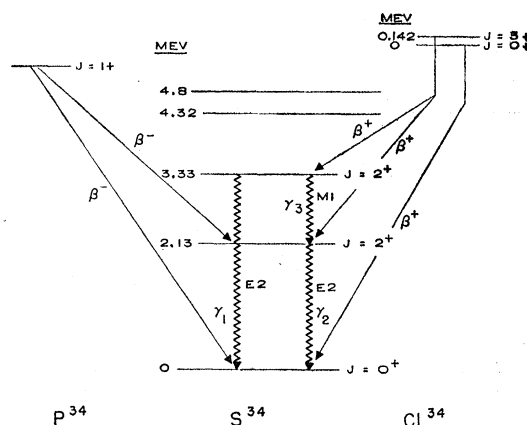

FIG. 7. Excited states of S^{34} .

F. Energy of the Fourth Excited State of S^{34}

A measurement of proton range in aluminum at 90° observation has given evidence of a fourth excited state at 4.8 ± 0.1 Mev.[§]

IV. GAMMA RAYS FROM THE SECOND EXCITED STATE OF S^{34}

Figure 6 shows the spectrum of the second-excited-state gamma rays. Three gamma rays are present, of energies 3.33, 2.13, and 1.20 Mev, which we will designate γ_1 , γ_2 , and γ_3 respectively (see Fig. 7). As indicated by the dotted lines in Fig. 6, the second pair peak of γ_1 overlaps the photopeak of γ_2 , and the second pair peak of γ_2 overlaps the photopeak of γ_3 . By making various assumptions as to the areas under the dotted peaks, the values 2.5 and 3.5 were obtained as extremes for the ratio of the areas under the photo, Compton, and pair peaks of γ_2 and γ_1 . Therefore the mean value of 3.0 was used, which, when corrected for the detecting efficiency of sodium iodide as a function of gamma-ray energy, gives 2.7 ± 0.5 for the $\gamma_2:\gamma_1$ intensity ratio (and therefore for the $\gamma_3:\gamma_1$ intensity ratio).^{||}

The relative-probability figure of 2.7 can be used in conjunction with Weisskopf's lifetime relations to deduce a certain amount about the spins and parities of the first and second excited states. Using the measured energies of the three relevant gamma rays (see above), the transition probabilities as given in Table II can be computed.

Since a resolving time of 6×10^{-8} second was sufficient to give approximately the coincidence counting rate

[§] Note added in proof.—Since the present paper was submitted for publication, the energy levels of S^{34} have been measured by Endt, Paris, Sperduto, and Buechner [Bull. Am. Phys. Soc. Ser. II, **1**, 223 (1956)] using a Van de Graaff generator and a magnetic spectrometer. They report levels in S^{34} at 2.127, 3.302, 3.915, 4.073, 4.114, 4.621, 4.685, and 4.876 Mev.

^{||} Note added in proof.—A cascade-to-crossover intensity ratio of 2.2 ± 0.4 has been obtained by David Green (thesis, University of California at Los Angeles, unpublished). [J. Reginald Richardson (private communication).]

TABLE II. Transition probabilities for a nucleus of mass 34, computed from the Weisskopf relations.^a

Energy, Mev	Type of radiation							
	<i>E1</i>	<i>M1</i>	<i>E2</i>	<i>M2</i>	<i>E3</i>	<i>M3</i>	<i>E4</i>	<i>M4</i>
γ_1 :3.33	6.37(16)	1.15(15)	8.38(12)	1.51(11)	7.23(8)	1.30(7)	4.21(4)	7.58(2)
γ_2 :2.13							7.53(2)	1.35(1)
γ_3 :1.20	2.98(15)	5.37(13)	5.09(10)	9.17(8)	5.71(5)	1.03(4)	4.32(0)	7.78(-2)

^a Quantities in parentheses are powers of 10.

that would be expected from the geometry of the experiment, it appears probable that no lifetimes longer than, say, 10^{-6} sec were present. Allowing a factor of 10^8 for the roughness of the theoretical estimates, it appears from Table II that we can reject multipolarity 4 or greater for any of the three gamma rays, with the possible exception of *E4* for γ_1 . This limits the spin of the first excited state to 3 or less. Moreover, this level cannot have spin zero, for there would then be no gamma transition from there to ground.

The transition probabilities of Table II were used to compute the $\gamma_3:\gamma_1$ intensity ratio for all possible spin-parity combinations of the first two excited states consistent with the above.

The assumption has for the moment been made that none of the gamma rays was a mixture, but that these transitions "proceed by emission of pure multipole radiation of the lowest multipole order *l* permitted by the selection rules, the radiation being electric or magnetic depending on the parity change in the nuclear transition."²⁴ It has also been assumed that the ground state of S^{34} is $0+$.

When those spin-parity combinations are rejected which lead to calculated $\gamma_3:\gamma_1$ transition probability ratios which differ from the experimental value of 2.7 by more than a factor of 10^3 , there are left those combinations listed in Table III.

Table III is the best that the present data, alone, can do. But when the results of β -decay experiments are considered, all but one of the combinations in Table III can be eliminated: It has been shown⁷ that the spin

TABLE III. Gamma-ray intensity ratios close to 2.7, with associated spin-parity combinations, as computed from the Weisskopf lifetime relations.

γ_1	Second exc. state	γ_3	First exc. state	$\gamma_3:\gamma_1$
<i>E1</i>	$1-$	<i>E1</i>	$1+, 2+$	0.047
		<i>E1</i>	$1-, 2-$	2.6
<i>M1</i>	$1+$	<i>M1</i>	$1+, 2+$	0.047
<i>M2</i>	$2-$	<i>M1</i>	$1-, 2-, 3-$	360
		<i>E1</i>	$1-, 2-, 3-$	360
<i>E2</i>	$2+$	<i>M1</i>	$1+, 2+, 3+$	6.4
		<i>E2</i>	$1-$	70
<i>E3</i>	$3-$	<i>M2</i>	$1+$	1.3
<i>M3</i>	$3+$	<i>M2</i>	$1-$	70
		<i>E3</i>	$1-$	14
<i>E4</i>	$4+$	<i>M3</i>	$1+$	0.24

²⁴ See reference 5, p. 634.

of the first excited state is definitely $2+$, which leaves as possibilities for the second excited state only $1\pm$ or $2+$. Now the β transition from the $3+$ state of Cl^{34} to the second excited state of S^{34} is allowed.⁷ It follows from the Gamow-Teller selection rules that the 3.33-Mev level of S^{34} could be $2+$, $3+$, or $4+$ only, and since we have eliminated $3+$ and $4+$ ($\gamma_3:\gamma_1=4.1\times 10^6$ and 1.2×10^6 respectively) by means of the coincidence experiment, it is concluded that the second excited state of S^{34} has spin 2 and even parity. This result is in agreement with the preliminary result of a gamma-gamma directional correlation in the Cl^{34} - S^{34} decay by Handler and Richardson.^{25,¶}

V. DISCUSSION

We have concluded that the first two excited states of S^{34} decay as shown in Fig. 7. The computed $\gamma_3:\gamma_1$ intensity ratio of 6.4 (Table III) compares well with the experimental value of 2.7. In fact, if one makes the tenuous assumption that theory and experiment agree for *M1* transition probabilities,²⁶ it follows that the theoretical calculation for the probability of the *E2* transition γ_1 is 2.4 times too small, a result which agrees qualitatively with other observations of *E2* transition probabilities.²⁶

Only pure multipole radiation has thus far been considered. If in reality γ_3 is a mixture of *E2* and *M1* radiation, then the theoretical *E2*:*M1* transition probability ratio for γ_3 is off by a factor of 10^3 . We observe also that in this case an *E2* transition of 1.2 Mev would be successfully competing with an *E2* transition of 3.33 Mev, although the latter should theoretically be faster by a factor of $(3.33/1.20)^5 \approx 160$. It is therefore unlikely that γ_3 contains as much as 0.3% of *E2* radiation. This supports the qualitative conclusion of Handler and Richardson.^{25,¶}

The writers are indebted to Professor Waldo Rall for suggesting the experiments, and for much helpful advice and discussion.

²⁵ H. E. Handler and J. R. Richardson, Phys. Rev. **98**, 281 (1955).

¶ *Note added in proof.*—The final results of Handler and Richardson [Phys. Rev. **102**, 833 (1956)] support the $2+$ assignments for the first two excited states of S^{34} and indicate that γ_3 is 1.7% electric quadrupole and 98.3% magnetic dipole radiation.

²⁶ See reference 5, p. 633; also M. Goldhaber and A. W. Sunyar, in *Beta and Gamma-Ray Spectroscopy*, edited by K. Siegbahn (Interscience Publishers, Inc., New York, 1955).